



**DOMINO
CLAMPS®**

The smartest way to attach almost anything to shipping containers



Mechanic International
Your specialist in security locks and containers

Domino Clamp Technical Sheet

Dimensions

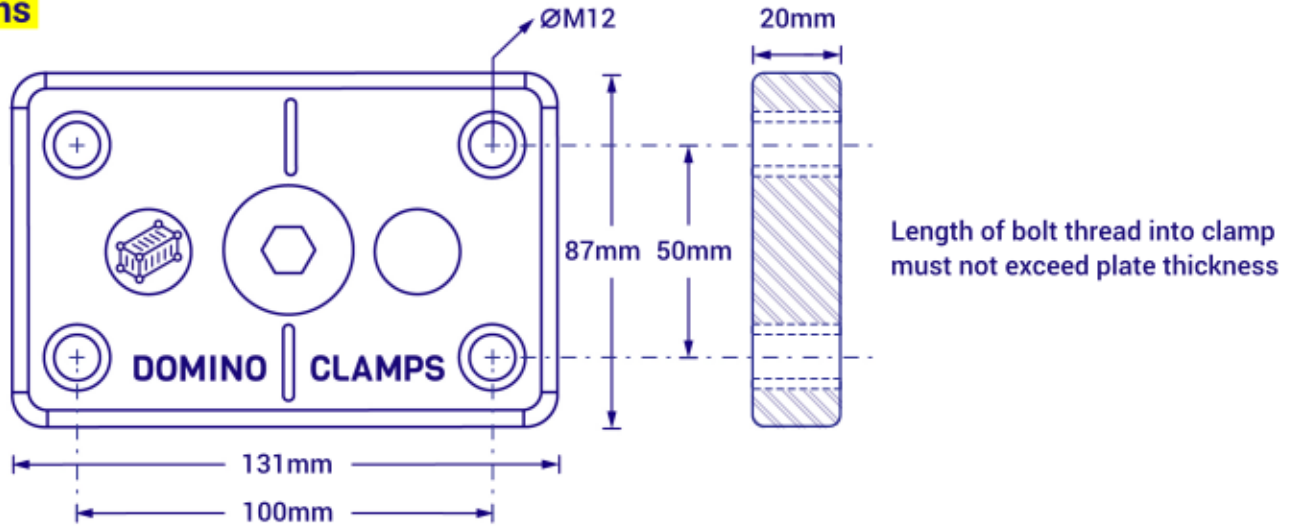

Recommended working loads



Side Holes
(stadium shape)

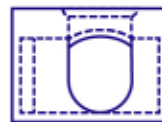
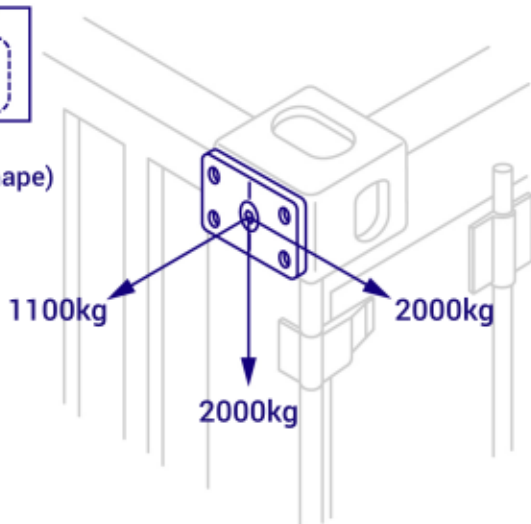

Top end holes
(Shield Shape)

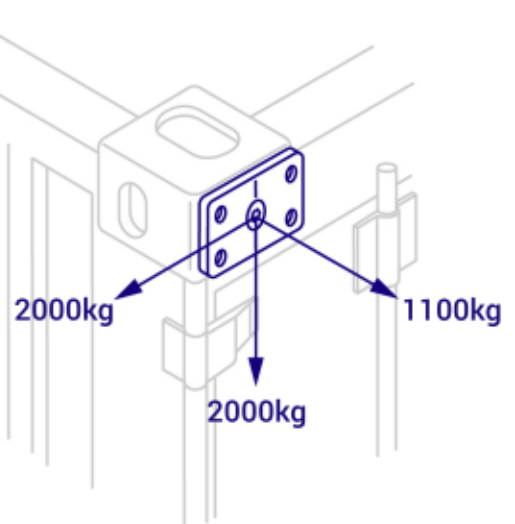

Notes

Factor of safety between ultimate & working loads: 5:1
For use only with ISO 1161 standard corner castings.
Clamp is to be used in front and side of corner casting as shown only.
Use only supplied Grade 10.8 custom bolt for tightening.

Max torque tightening bolt: 20Nm

In long term installations, check tightening bolt at regular intervals.

If the clamp is subject to constant vibration, we advise the use of a thread locking liquid on the centre bolt.

Material Specification:

Forged Steel Grade EN3B (070M20)

European Standard EN10083-1

Coatings:

Base layer: Electroplated zinc

Finish: Xylan 1010



MAX TORQUE
20Nm



USE ONLY WITH
ISO1161 CASTINGS

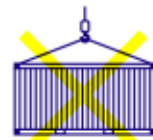

NOT FOR LIFTING



NOT FOR USE IN TOP
OR BOTTOM HOLES